

MINOR
PENTATONIC

Scale Chart

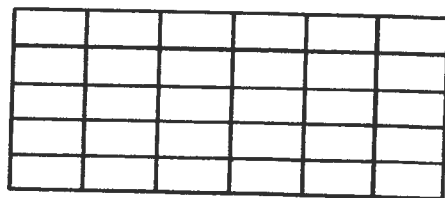
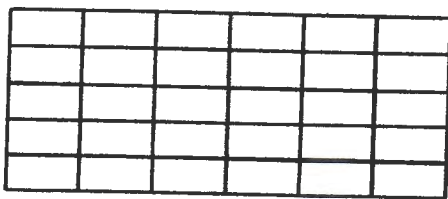
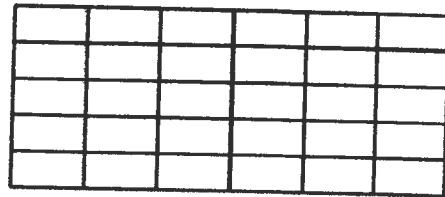
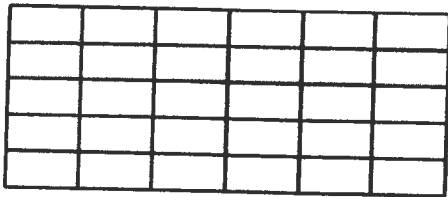
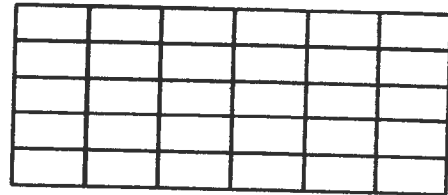
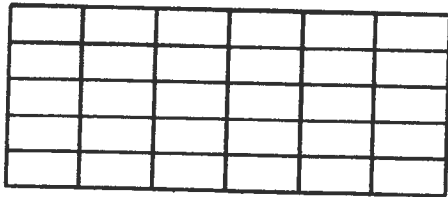
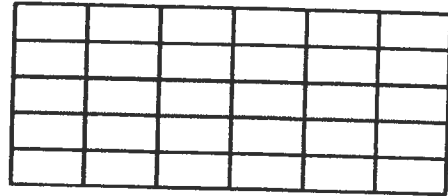
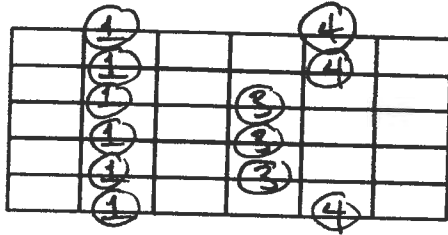

MAJOR "COWBOY CHORDS" #1

E MAJOR

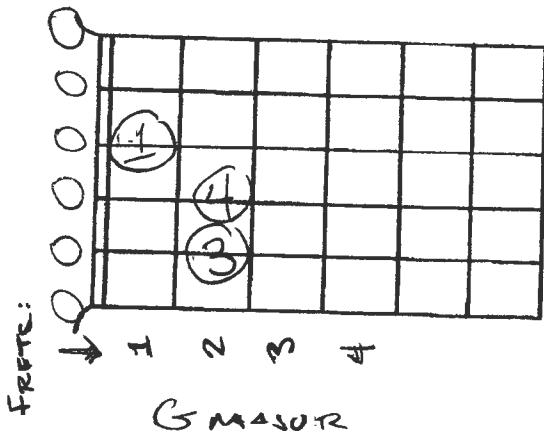

A MAJOR

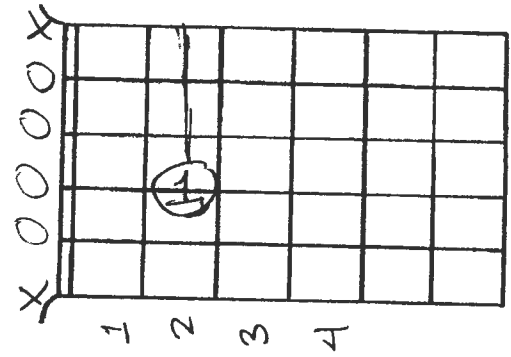

G MAJOR

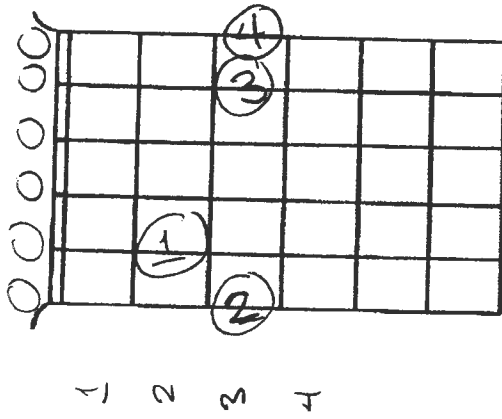

C MAJOR

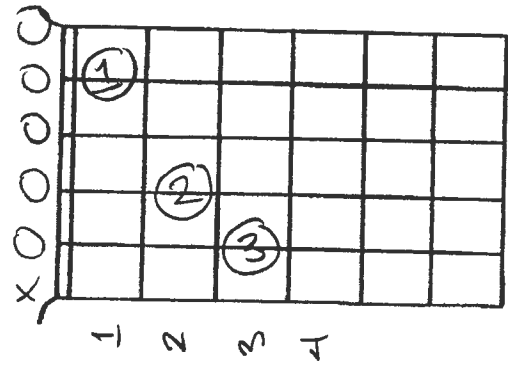

MAJOR 'COWBOY' #2 CHORDS

D MAJOR

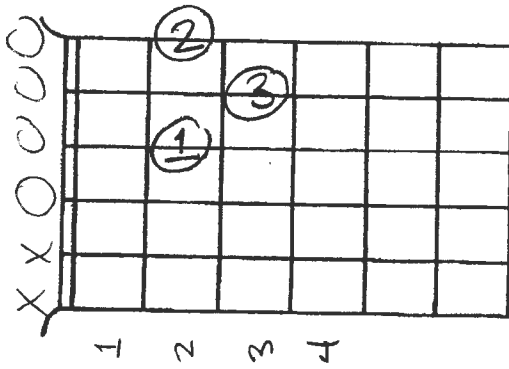

F MAJOR

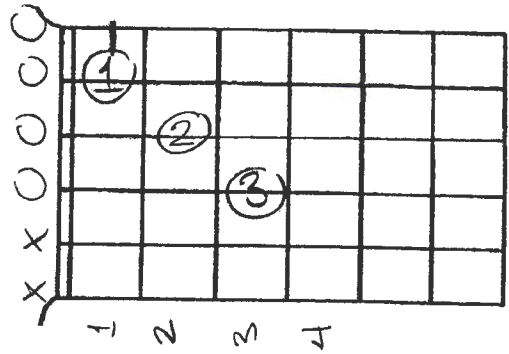

B MAJOR

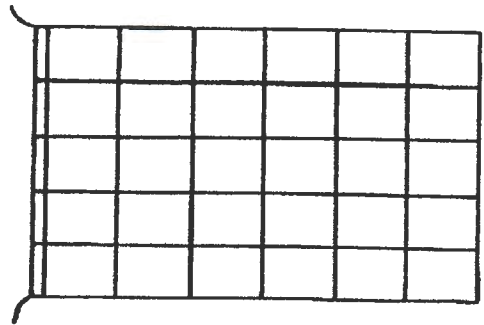
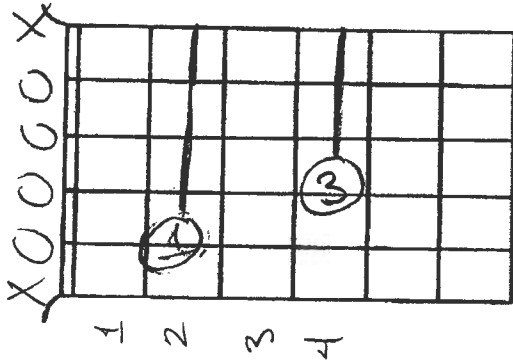

Standard Tuning Fretboard

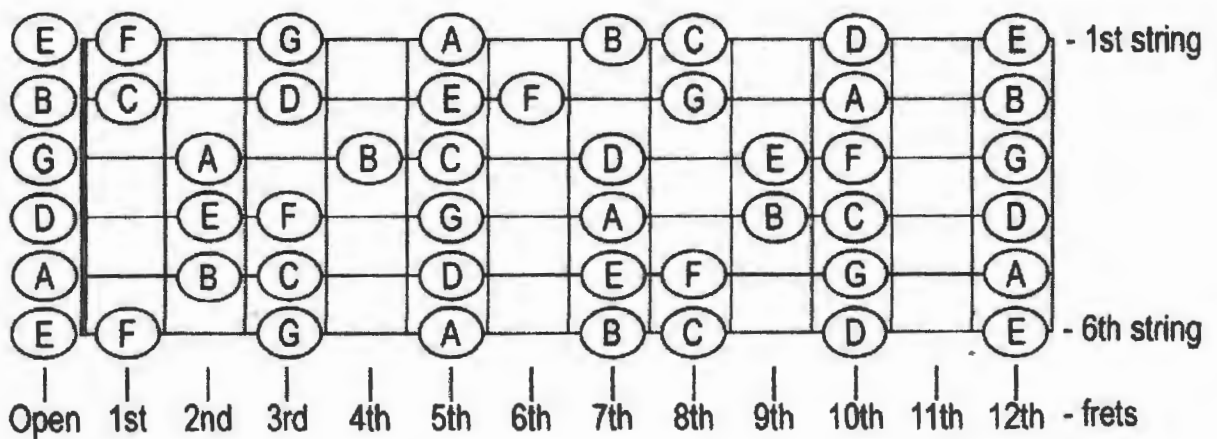
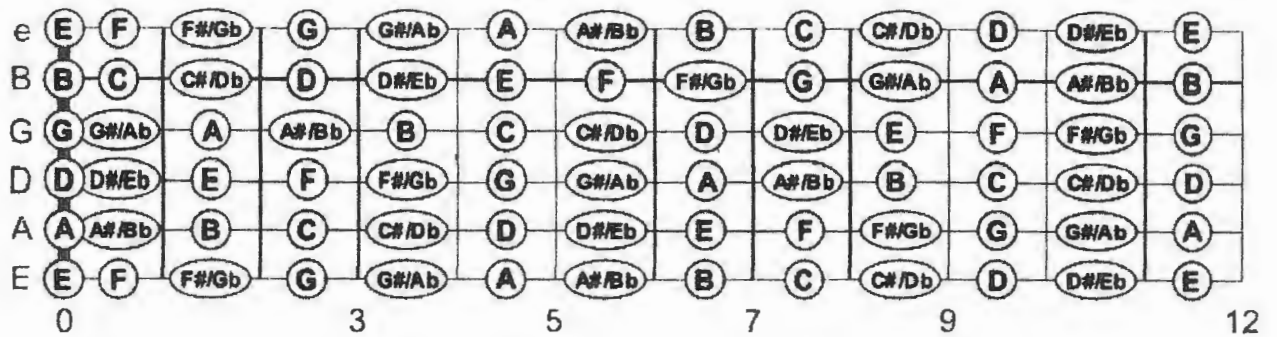

Positions shown
in Roman Numerals

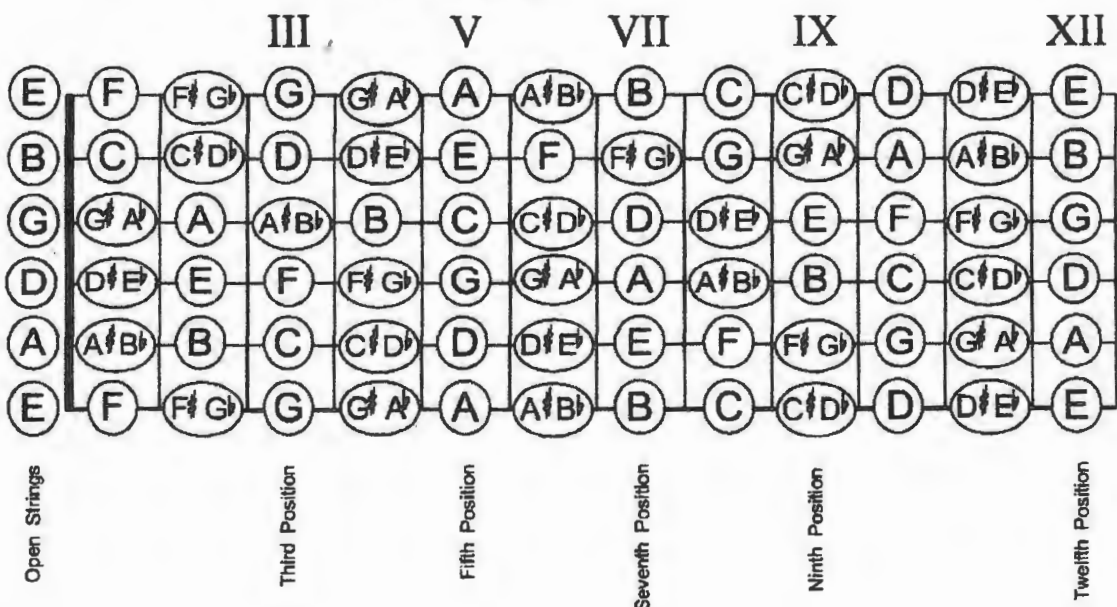

MAJOR CHORDS SHAPES

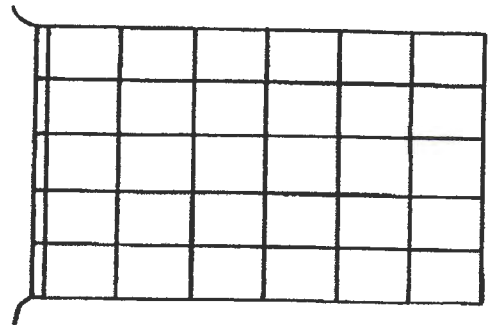
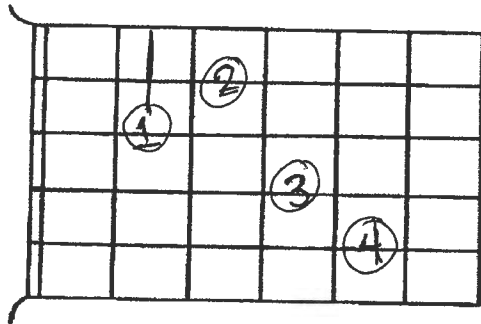
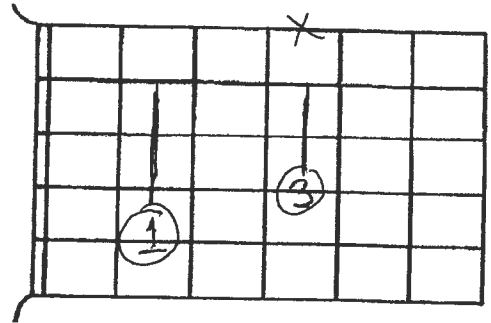
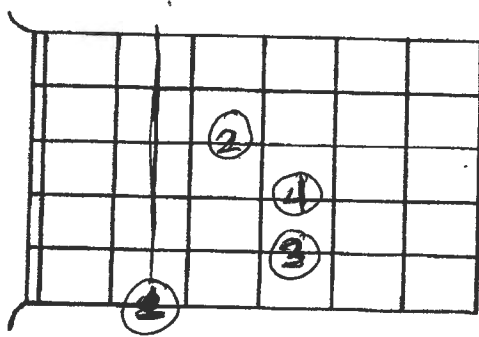

MINOR CHORD SHAPES

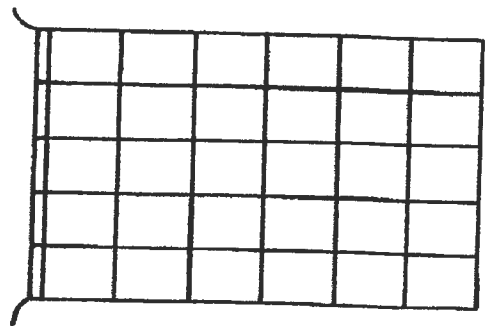
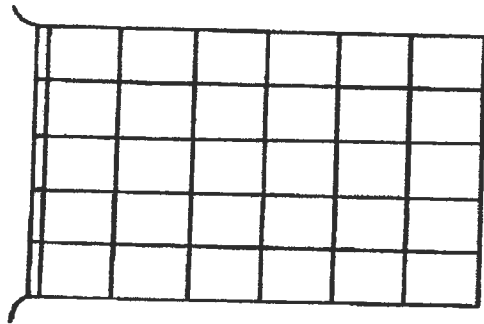
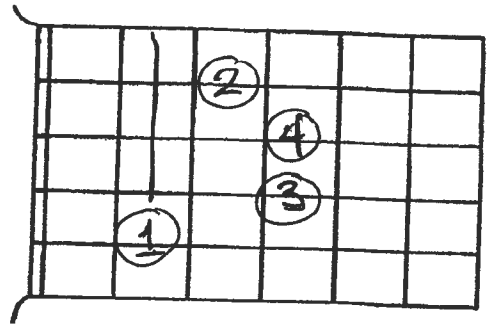
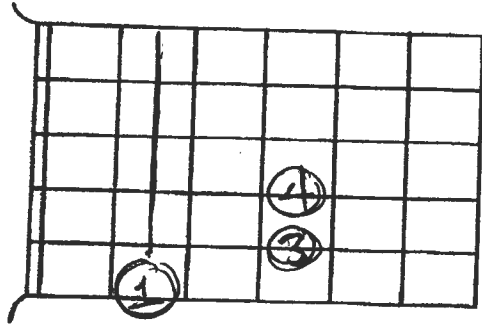

MAJOR 7th CHORD SHAPES

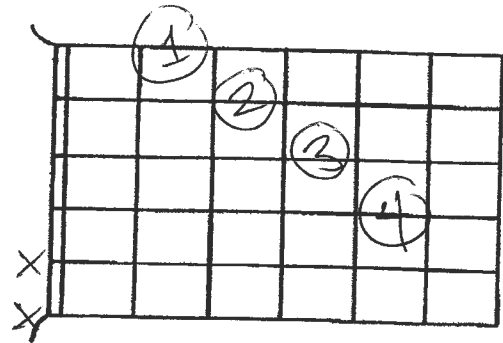
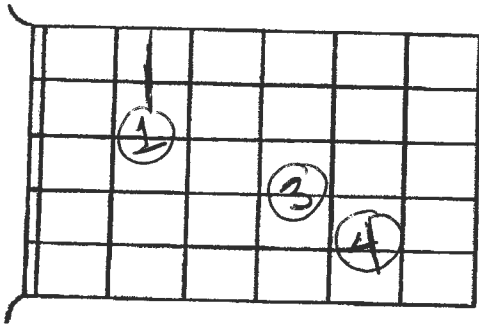
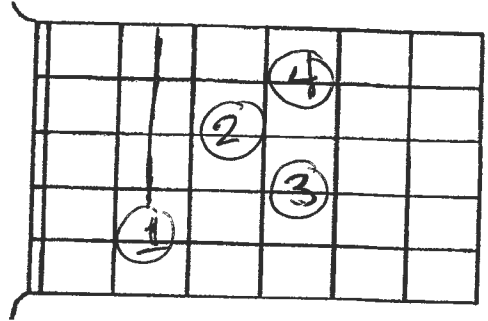
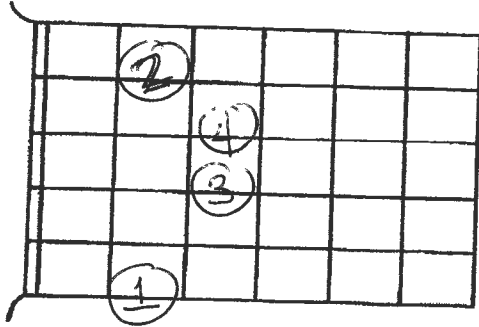

MINOR 7th CHORD

SHAPES

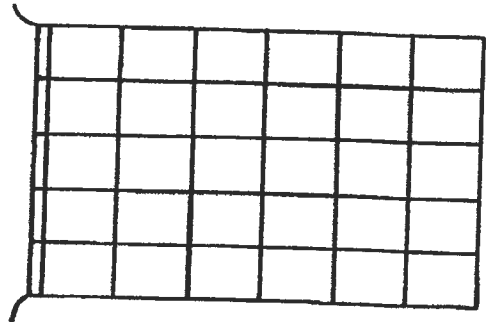
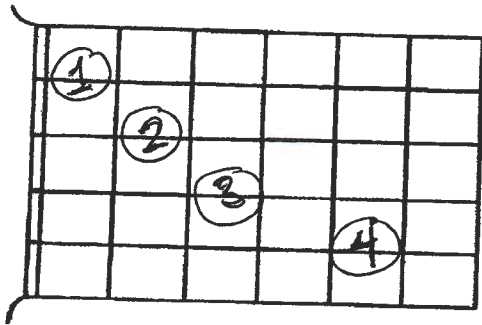
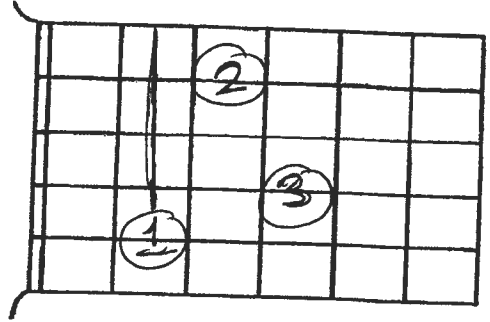
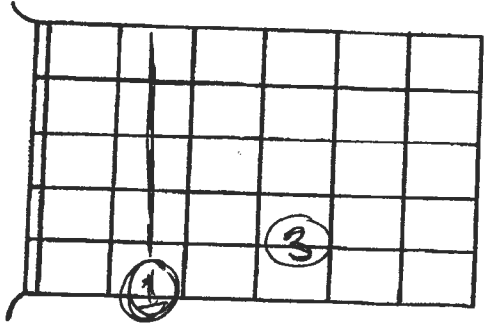

DOMINANT
7TH

CHORD
SHAPES

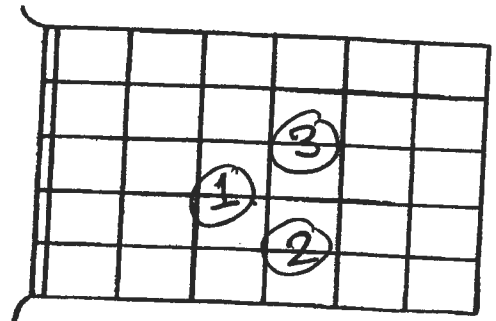
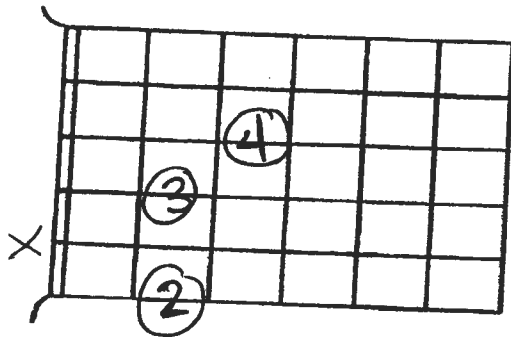
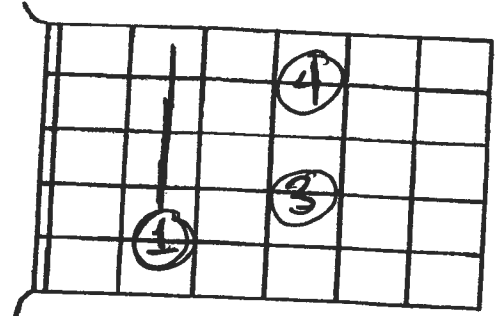
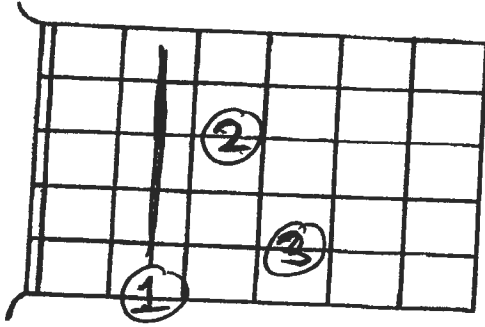

DIMINISHED 7th CHORD SHAPES

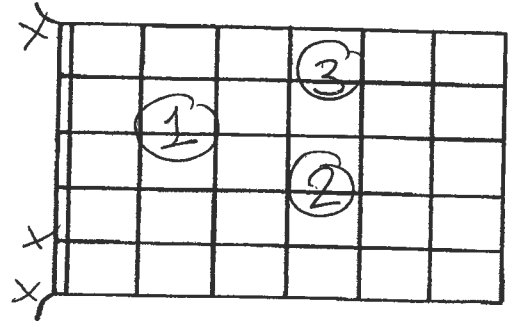
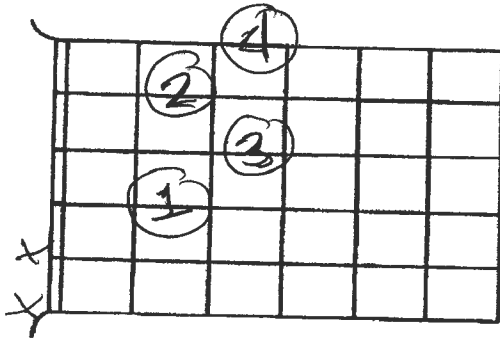
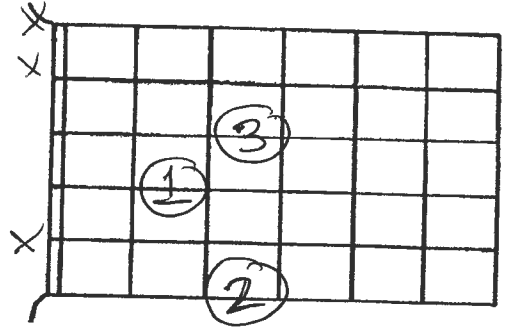
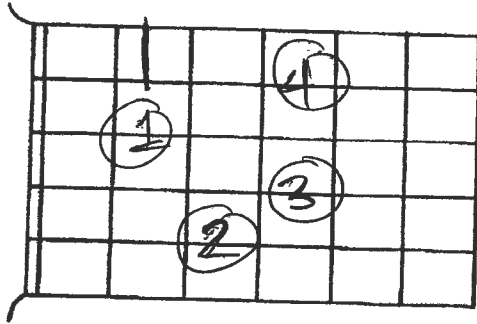

Scale Chart #1

MINOR PENTATONIC

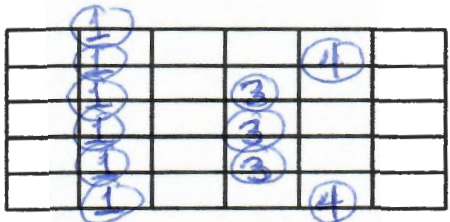

MAJOR

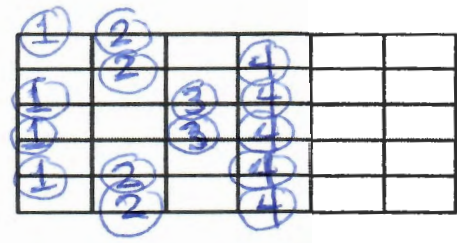

NATURAL MINOR



MINOR BLUES

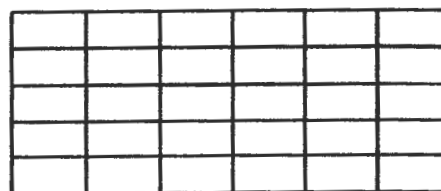
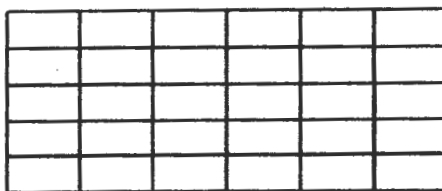
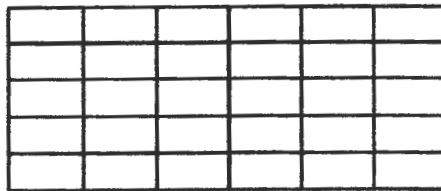
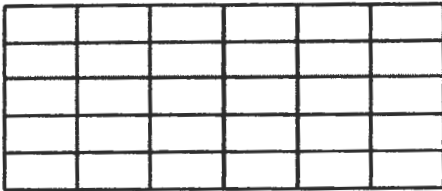
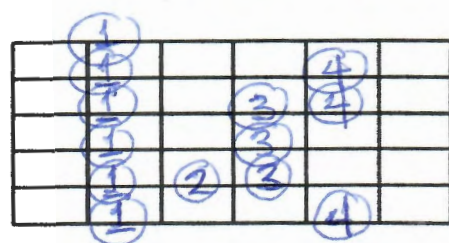

MAJOR*

Scale Chart FINGERING

NATURAL
MINOR

		1	2		
	1		2	4	
	1		2	4	

		1		3	
		1		3	4
		1		3	4

(2 octaves)

		1		3	4
	1	2		4	
	1	2		4	
1		2		4	
1		2		4	

* main focus for basic harmony

MAJOR DIATONIC CHORDS SHAPES

I
MAJOR

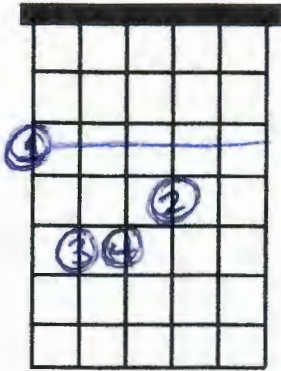

II, III
MINOR

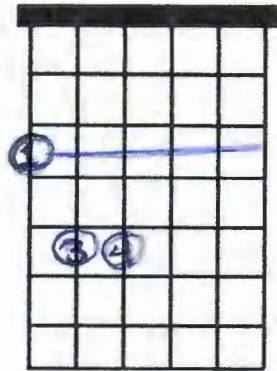

IV, V
MAJOR

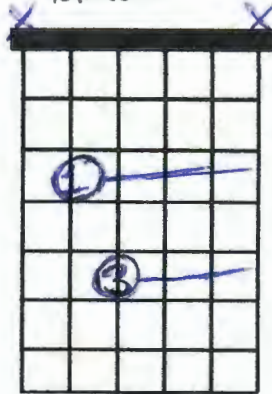

VI
MINOR

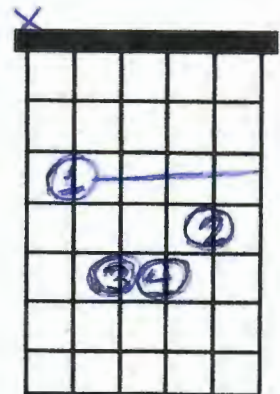

VII
DIMINISHED

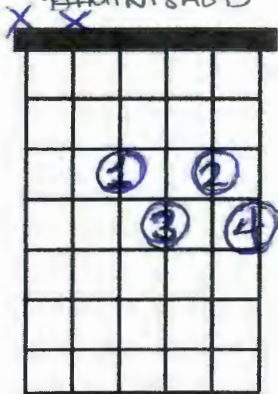

VIII
MAJOR

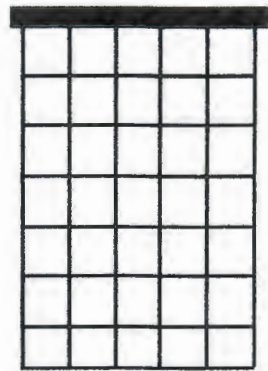
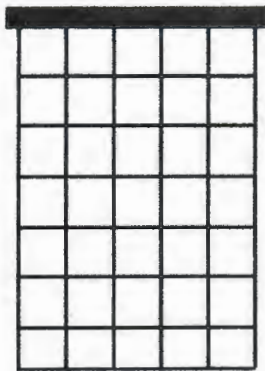
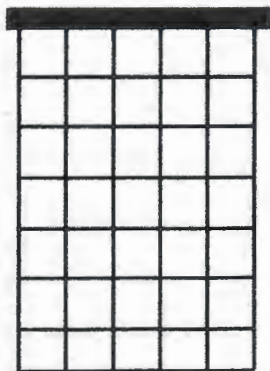
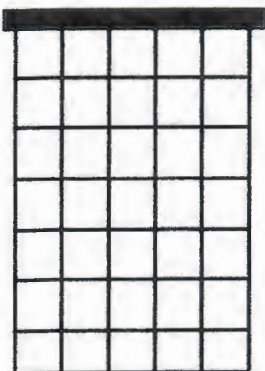
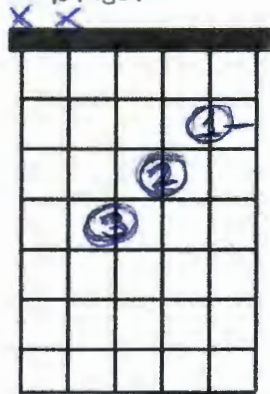

MAJOR DIATONIC CHORD SHAPES W/ ADDED 7th

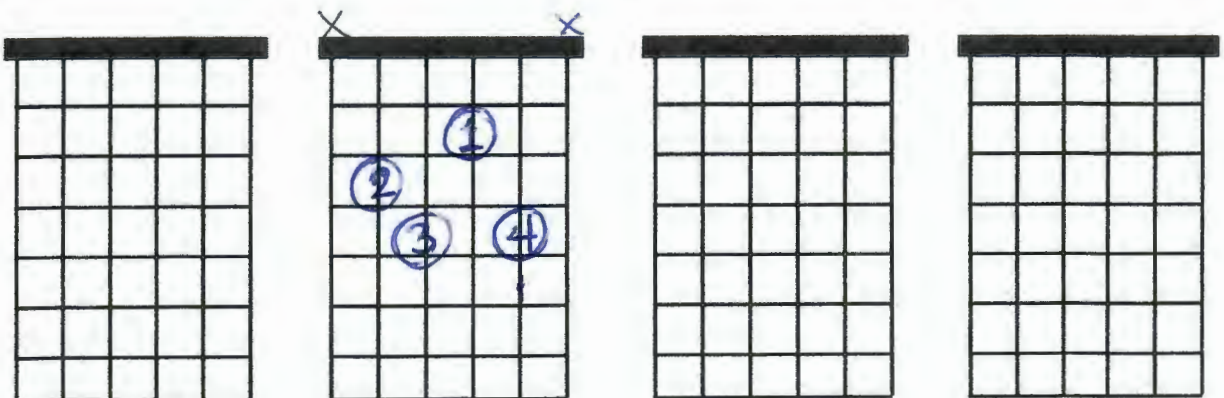
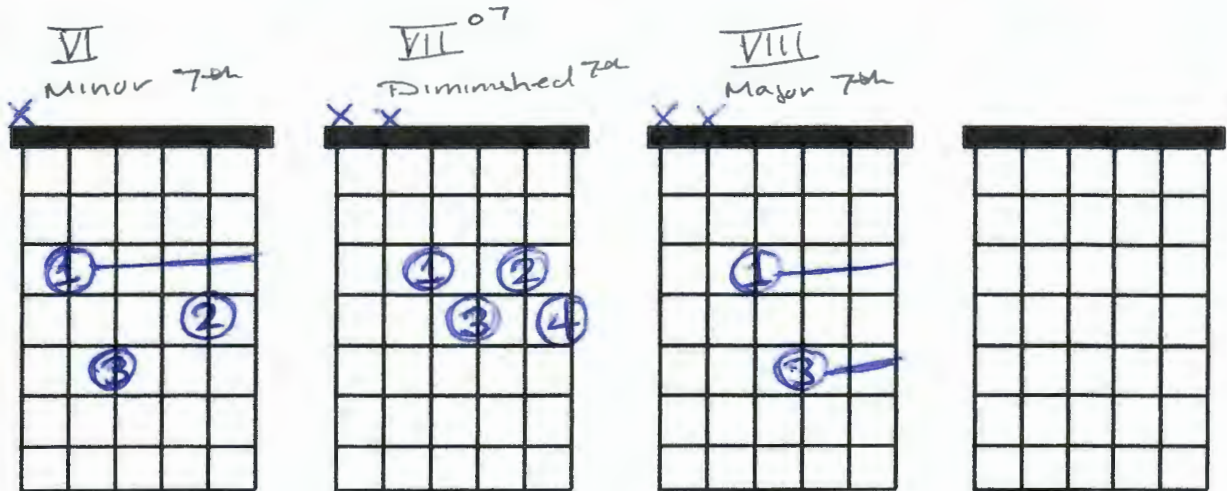
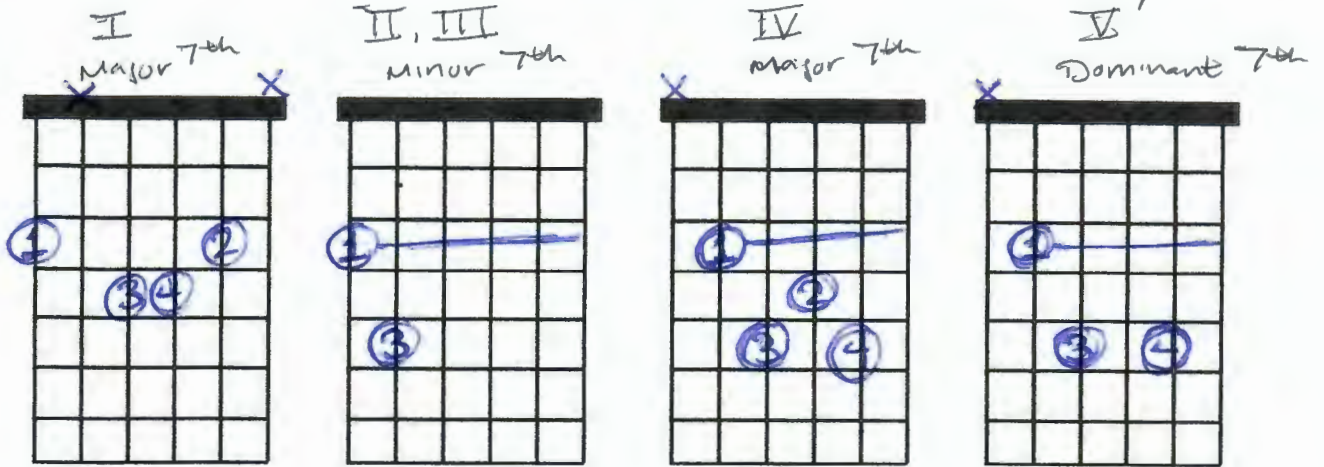

"Special" Chord TYPES

b7sus4
Dominant 7th,
sus 4th

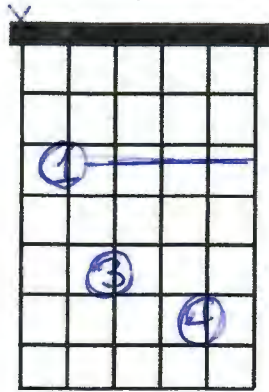

•/•

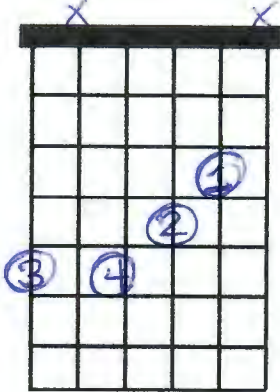

sus2nd

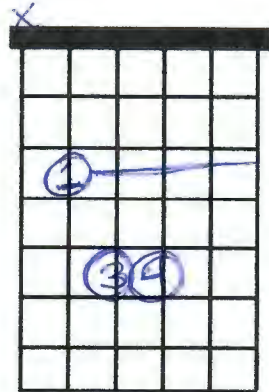

•/•

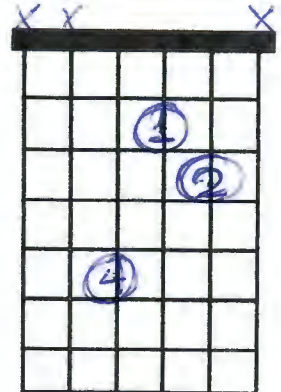

1st inversion
• major w/ 3rd
in bass

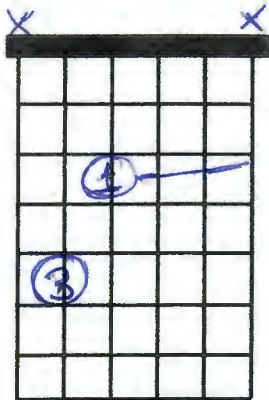

•/•

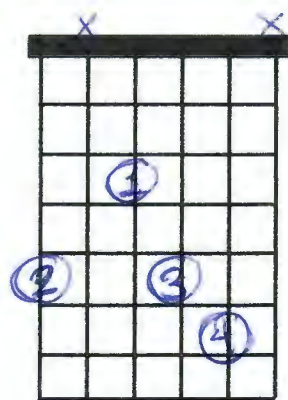

2nd inversion
• major w/ 5th
in bass

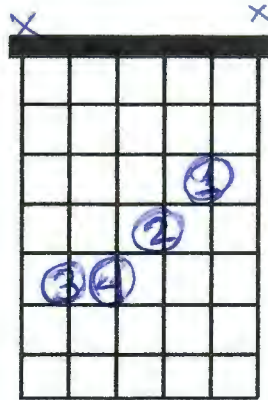

•/•

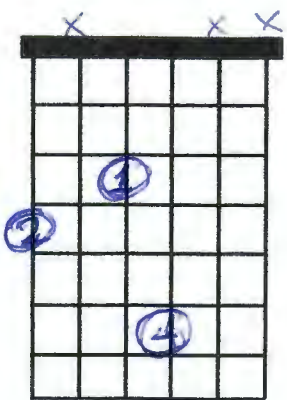

Half diminished
(min 7th or b5)

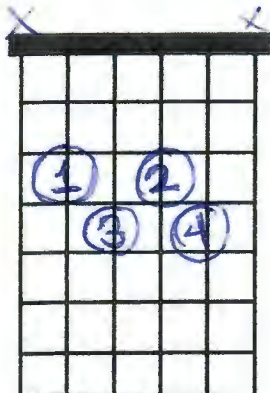

•/•

